

CCNA Semester 4 - Skills Based Final Exam - Student Training **Instructor Guidelines - Exam Overview and Administration**

This exam is for use with regular CCNA classes taught by local academies to high school and college students. The skills-based exam consists of three parts; 1) Router Configuration, 2) Subnetting, 3) Network Concepts. All three parts should be completed (total possible of 100 points) and the total score combined with the Semester 4 online assessment exam to establish a course grade. Scores from chapter exams and completion of labs, as well as points for participation and attendance may also count toward the final grade.

The guidelines presented here are recommendations and instructors have flexibility in assigning point values and administering the exam based on their classroom environment and schedule. Emphasis should be on the hands-on portion of the exam. Students should be made aware of what they will be tested on early in the course in order to study and prepare adequately for the exam.

The exam may be administered by dividing the class into groups (teams) of five. Try to ensure that teams are evenly matched with a variety of skill levels. Teams should be formed about 2/3 of the way through the class to allow them time to work together and to minimize team dropout. Part 1 will require access to one router per student. Five students can be tested simultaneously on part 1 while another group is working on Parts 2 Subnetting and 3 the Network Concepts.

Exam Part 1 – Router Configuration – (Practical hands-on, Max. time 40 min., 60 Points)
Objective: Manually configure a router and an attached workstation according to a given scenario which defines specific requirements. The router will attach to a fictitious network router whose configuration is known. A WAN link using Frame relay will need to be configured. An Access Control List (ACL) must be applied to block certain traffic. Each student will configure one router and an attached workstation.

Preparation / Tools: Standard 5-router / workstation lab setup. Workstations should have HyperTerminal and a TFTP server installed. Backups of the configuration files for all 5 routers on floppy or CD should be available for quick restore.

Exam Part 2 - Subnetting Exercise– (Written exercise, Est. time 20 min., 20 Points)
Objective: Given some basic IP addressing information for a network such as a host IP address and subnet mask, determine other IP related information such as number of subnets, hosts per subnet, subnet address, broadcast address, host address range etc.

Preparation / Tools: Develop a list of 5 to 10 scenarios with a few pieces of IP information given and the remaining information to be determined by the student. Some examples are included.

Exam Part 3 - Network Concepts – (Oral or Written, Est. time 20 min., 20 Points)
Objective: Answer 2 questions on semester 4 networking concepts from a pool of approved questions. Any student may have to answer any question and should know the questions ahead of time. Responses may be given verbally to the instructor / proctor or written.

Preparation / Tools: List of questions and rubric which can be found in the instructor's version of the Semester 4 curriculum in the Preface, Chapter 0 under Fourth Semester Finals.

Semester 4 Skills Based Final – Part 1 Router Configuration Student Training – Frame Relay Scenario – (60 pts)

Configuring the Headquarters Router

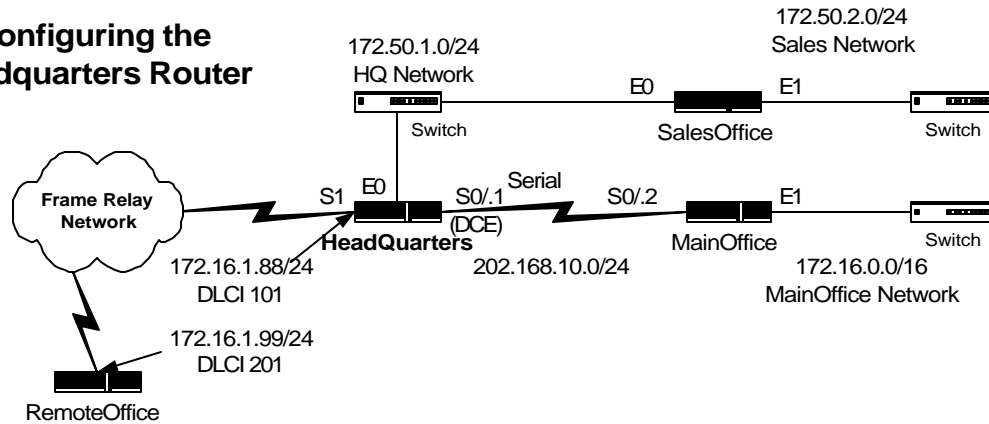

You will only be configuring the **Headquarters** router. Assume all other routers have been configured. Because the other routers are not physically present, the **Headquarters** router will not show any connectivity to these routers and their networks. Save your running-config to the startup-config often. Configure your router based on the following requirements. Copy your running config to a floppy with your name on it and hand it in when you are finished.

Router Configuration Requirement	Pts/initials
Configure the router hostname to be HQ , with your initials at the end (ex: HQ-JRL)	3 pt/
Configure the enable secret password to be “ class ”	3 pt/
Configure the password to be “ cisco ” for log in from the console port.	3 pt/
Configure the password to be “ cisco ” for telnet into the router.	3 pt/
Configure IP addresses for all Headquarters router interfaces. If a host IP address is not shown use any valid address for that subnet.	5 pt/
Add a description to each interface describing the link	3 pt/
Configure the Serial 1 interface with Frame Relay encapsulation	5 pt/
The RemoteOffice router has an IP address of 172.16.1.99. Assume Inverse-ARP is disabled and add a statement that will allow Headquarters to be mapped to the remote router’s IP address.	5 pt/
Between Headquarters and MainOffice , use PPP encapsulation with CHAP authentication. Headquarters provides the clocking.	5 pt/
Configure a static hostname mapping for the MainOffice router, so the user can “ping <i>MainOffice</i> ” instead of using “ping 172.16.0.x”.	3 pt/
Configure the router to use the domain name server at 172.50.1.10	3 pt/
Add a message of “Authorized access only!” to display before log into the router.	3 pt/
Add IGRP routing to the 172.50.0.0 network with Autonomous System number 10	3 pt/
Configure a static route from Headquarters to the 172.50.2.0 SalesOffice network	3 pt
Configure a static route from Headquarters to the 172.16.0.0 MainOffice network	3 pt/
Configure a default route so that all other traffic leaving the 172.50.0.0 network will travel to the RemoteOffice router.	3 pt/
Add an access list to the Headquarters Router that will deny telnets from outside the 172.50.0.0 network, into the 172.50.1.0 subnet. All other traffic is permitted.	4 pt/

Points Scored : (items above are correct or not, no partial points)

Semester 4 Skills Based Final – Part 2 Subnet Exercise

Student Training (20 pts)

Instructor note: In these examples, only the Host IP address and subnet mask are given. The student must fill in the missing information. You may develop your own exercises. Assign one exercise. Each correct answer in these examples is worth appx. 3 pts (7 blanks).

Subnetting: Exercise A

Show all work!

Host IP Address	Subnet Mask	Class	Maximum number of <u>usable</u> subnets	Maximum <u>usable</u> hosts per subnet	Major Network Address (Classful network address)
131.108.1.77	255.255.255.240				
Subnet Address of This Subnet or Wire		Range of Host Addresses For this subnet		Broadcast Address of This Subnet	

Subnetting: Exercise B

Show all work!

Host IP Address	Subnet Mask	Class	Maximum number of <u>usable</u> subnets	Maximum <u>usable</u> hosts per subnet	Major Network Address (Classful network address)
200.108.1.77	255.255.255.224				
Subnet Address of This Subnet or Wire		Range of Host Addresses For this subnet		Broadcast Address of This Subnet	

Subnetting: Exercise C

Show all work!

Host IP Address	Subnet Mask	Class	Maximum number of <u>usable</u> subnets	Maximum <u>usable</u> hosts per subnet	Major Network Address (Classful network address)
201.108.1.77	255.255.255.248				
Subnet Address of This Subnet or Wire		Range of Host Addresses For this subnet		Broadcast Address of This Subnet	

Semester 4 Skills Based Final – Part 3 Network Concepts
(Individual performance - 20 pts)

Objective:

Answer the 2 questions on semester 4 networking concepts as assigned by the instructor. Write the questions assigned in the space provided below. You may be asked to answer orally or write your answers on the back of this sheet. Answers should be as detailed as possible for maximum credit.

Instructor notes: Sample questions and rubrics to help assess answers are found in the instructor's version of the Semester 4 curriculum in the Preface, Chapter 0 under Fourth Semester Finals.

Questions 1 (10 pts):

Question 2: (10 pts)

Points Scored: _____

Semester 4 Skills Based Final – Part 1 Router Configuration

Instructor Guide - Headquarters Router running-config

Current configuration:

```
version 12.0
no service password-encryption
no service udp-small-servers
no service tcp-small-servers
!
hostname HQ-XXX
enable secret 5 $1$52gN$vKgKMADLsaSW6/57ksf7n1
username MainOffice password 0 class
!
interface Ethernet0
  description LAN Interface on HQ-Network
  ip address 172.50.1.1 255.255.255.0
  ip access-group 101 out
!
interface Serial0
  description WAN interface to MainOffice
  ip address 202.168.10.1 255.255.255.0
  encapsulation ppp
  clockrate 56000
  ppp authentication chap
!
interface Serial1
  description WAN interface to RemoteOffice
  ip address 172.16.1.88 255.255.255.0
  encapsulation frame-relay
  frame-relay map ip 172.16.1.99 101
!
router igrp 10
  network 172.50.0.0
  ip host MainOffice 172.16.0.1
  ip name-server 172.50.1.10
  no ip classless
  ip route 172.50.2.0 255.255.255.0 172.50.1.2
  ip route 172.16.0.0 255.255.0.0 202.168.10.2
  ip route 0.0.0.0 0.0.0.0 202.168.10.1
  ip access-list 101 deny tcp any 172.50.1.0 0.0.0.255 eq telnet
  ip access-list 101 permit ip any any
  banner motd ^C Authorized access only! ^C
line con 0
  password cisco
  login
line aux 0
line vty 0 4
  password cisco
  login
```